

STORFLEX FIXTURE CORPORATION

Customer Service
392 West Pultney Street
Corning, NY 14830

Telephone: (800) 869-2040 or (607) 962-2137
Fax: (607) 962-7655
Visit us at: www.storflex.com

SHELVING

INSTALLATION INSTRUCTIONS

WARRANTY

We warrant to the original purchaser that all products manufactured by us are free from defects in material and workmanship. Our obligation under this warranty is limited to repairing or replacing at our plant any part or parts which shall, within one (1) year after delivery to the original purchaser, be demonstrated to be thus defective under normal use and service. This warranty is in lieu of all other warranties, expressed or implied, and of all other obligations or liabilities of any kind on our part, and no modification of this warranty shall be valid or binding unless in writing and signed by an officer of our company.

IMPORTANT

Study all instructions and components before installing.

STORFLEX takes great care in packing and shipping STORFLEX shelving installations. Check for possible shipping damage or shortage prior to erecting units. Order replacements for any shortage or damaged parts directly from your STORFLEX Sales Representative or by calling Customer Service.

PARTS IDENTIFICATION

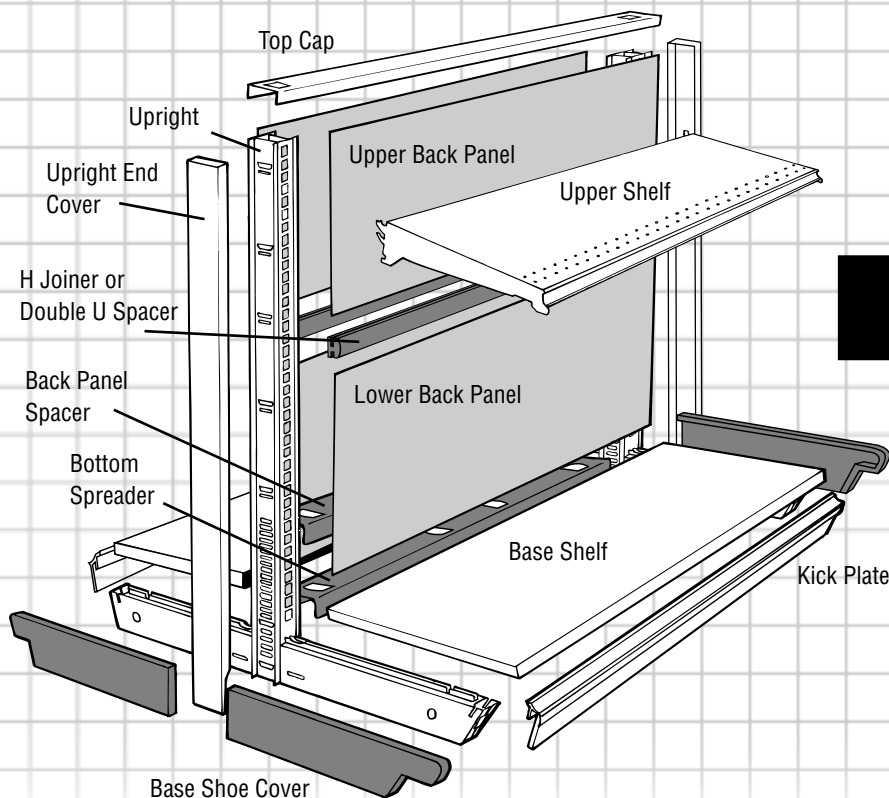

TOOLS REQUIRED

- Chalk Line
- Screwdrivers (long handled)
- Magnetic Level, Line Level or Transit
- Adjustable Wrench
- Small Pinch or Crowbar
- Braided Cord
- "T" Handle Wrench (Supplied)

UNLOADING

STORFLEX shelving installations are placed in the truck in a careful and systematic manner. Unload your shipment accordingly, stacking parts by type, in one place. This will aid in quicker and more efficient check in and assembly.

STORFLEX

STEP 1:

DETERMINE YOUR UPRIGHT CONSTRUCTION

- **Welded-In-Place** Base Shoes
 - **Detachable** Base Shoes
- If your system was supplied with base shoes already **WELDED IN PLACE**, go to **STEP 2**.

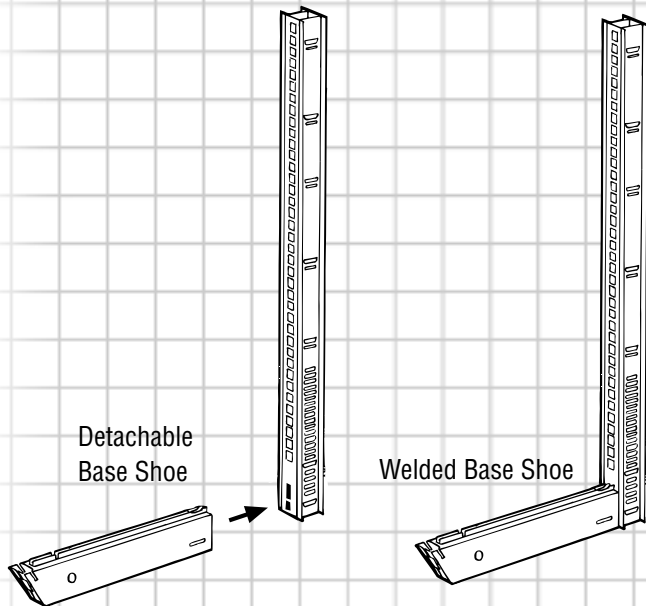

PARTS USED IN DETACHABLE SYSTEM

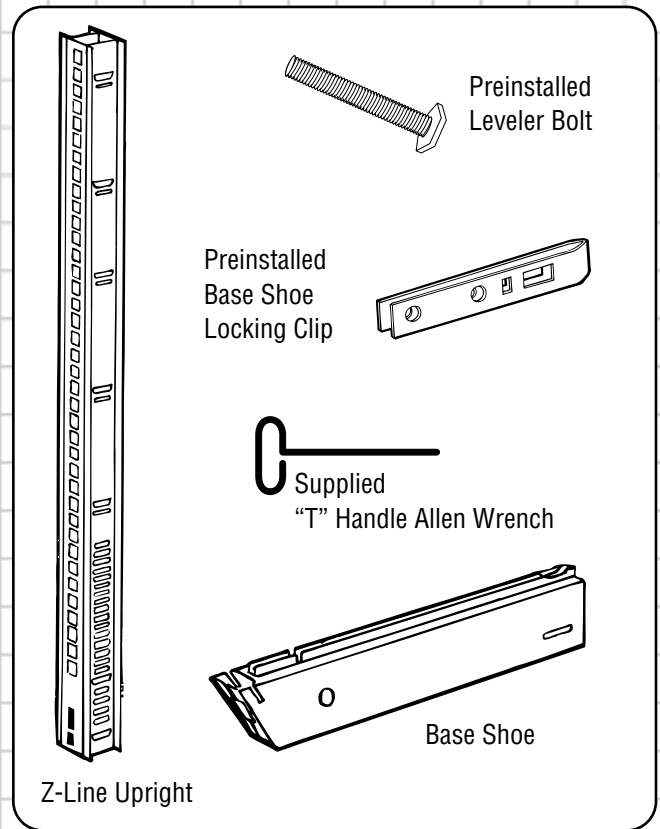

FOR DETACHABLE BASE SHOES FOLLOW THESE STEPS

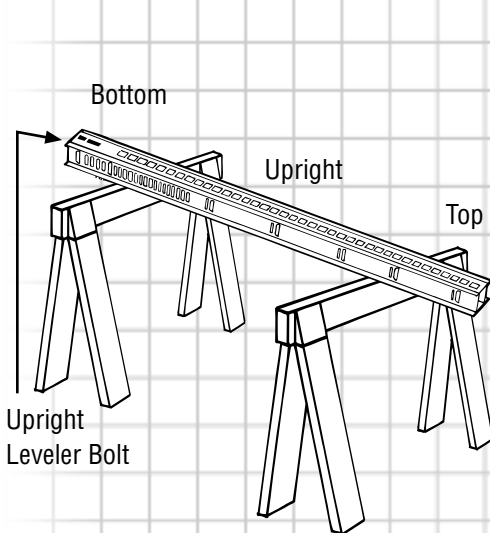

DETAIL A – Set the upright on two saw horses as shown.

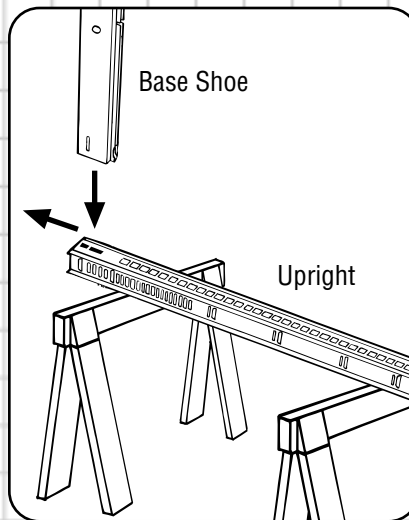

DETAIL B - Insert the separate base shoe into the upright and slide down to seat into place.

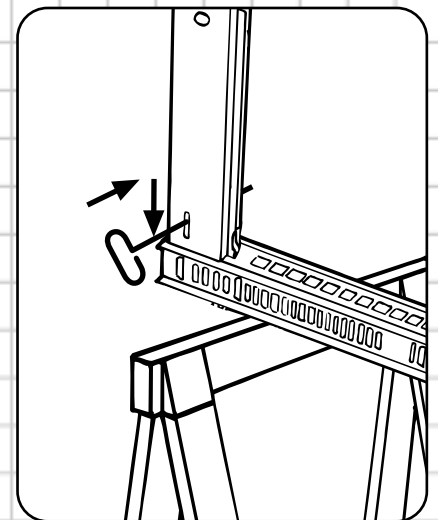

DETAIL D - Insert the supplied "T" handle allen wrench into the internal locking clip as shown and then press down with even pressure until the clip clicks once.

STEP 2: POSITIONING

Mark floor for run locations, utilizing a starting point at the front or rear of the store, and one for the outer edge of the shelving.

Following the fixture plan and layout dimensions, snap chalk lines on the floor so that major components can be placed and inventoried along the line in their approximate positions, and later aligned to those chalk guide lines.

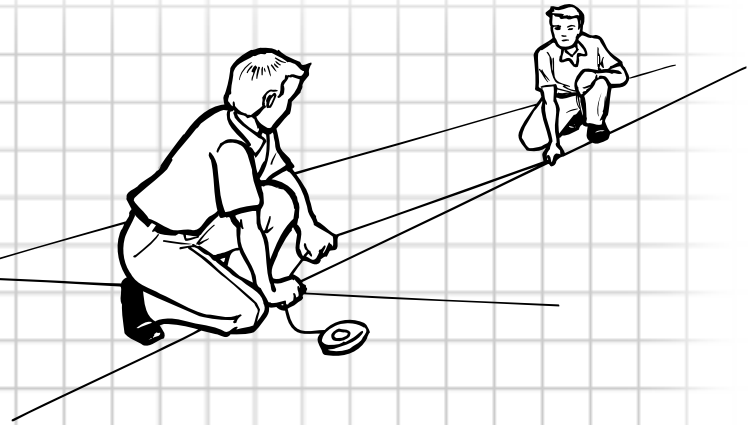

STEP 3: STARTING RUN (APPLICABLE TO HALF AND FULL GONDOLA SHELVING)

A. Snap an additional chalk line within each set of chalk guide lines that will represent the center-line of each run and establish the position of all uprights.

B. Determine the highest point in the floor along this center-line and mark the floor with an “x” at that point. (Use a laser or a string stretched tight at floor level to find high point.)

C. When leveling the shelving run, the center leveling bolt of the upright closest to the “x” should only be adjusted outward one half turn.

D. Level the run out and away in either or both directions from this upright.

E. If at any point in the process of the leveling it's found that the leveling bolts must be extended more than 1-1/4" outward, it is required to shim, under those uprights, with solid, stable shimming materials.

F. If offset loading conditions are going to exist (much heavier product on one side versus the other of a gondola) refer to “Offset Load Rating and Specifications Addendum” before continuing.

NOTE: Half gondola sections are required to be anchored to a wall.

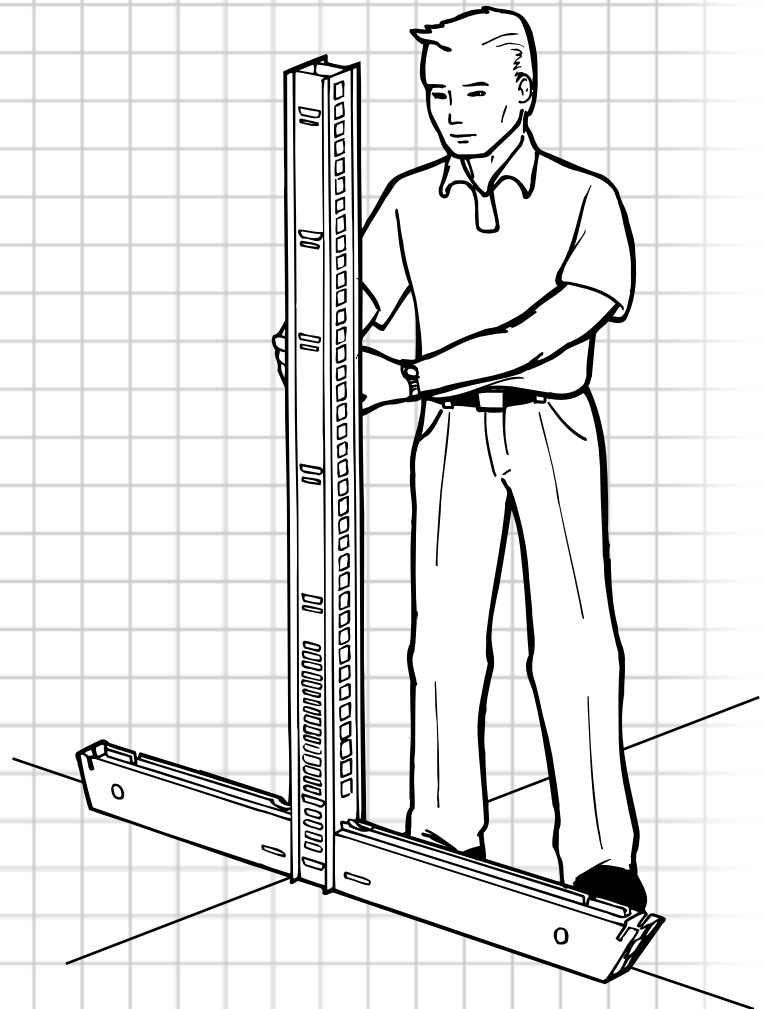

STEP 4: SPREADERS AND BACK PANEL SPACERS

While holding the first upright vertical and in place, insert and lock a bottom spreader into the bottom lance of the vertical upright. Raise the adjoining upright into the vertical position, insert and lock the other end of the bottom spreader into its bottom lance.

To stabilize this assembly, insert back panel spacers. (2 spacers in units up to 60" high, 3 spacers in units 78" or higher.)

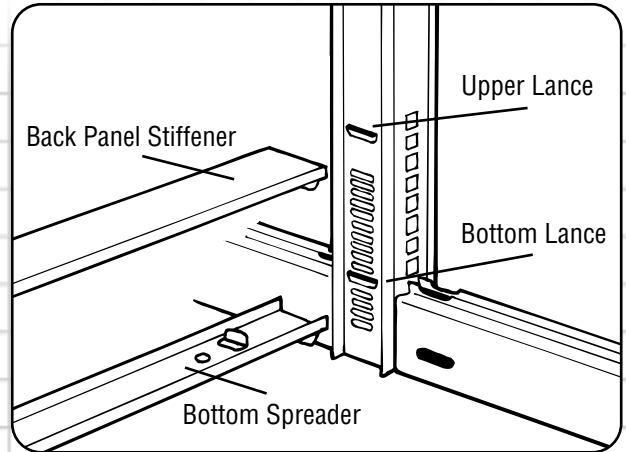

STEP 5: BACK PANEL(S)

A. Where Back Panels are one piece, slide first one Back Panel, then the second into position.

B. On 78" high and taller units where Back Panels are two piece, slide both Small Lower Panels into position first, then install H-Joiner or Double-U Channel second, followed by both large upper panels third.

C. Only install back panels in the starting section at this time.

D. Repeat Steps A & C in assembling the remaining metal framework of the entire shelving run.

E. Install remaining back panels. (A rough leveling of upright alignment may be necessary in order to install the back panels if an unlevel floor condition exists.)

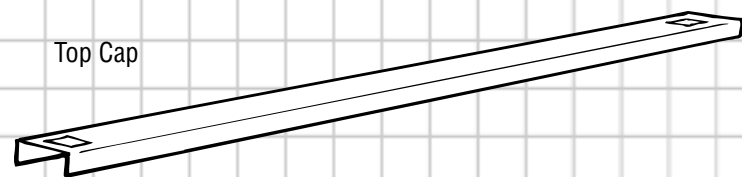
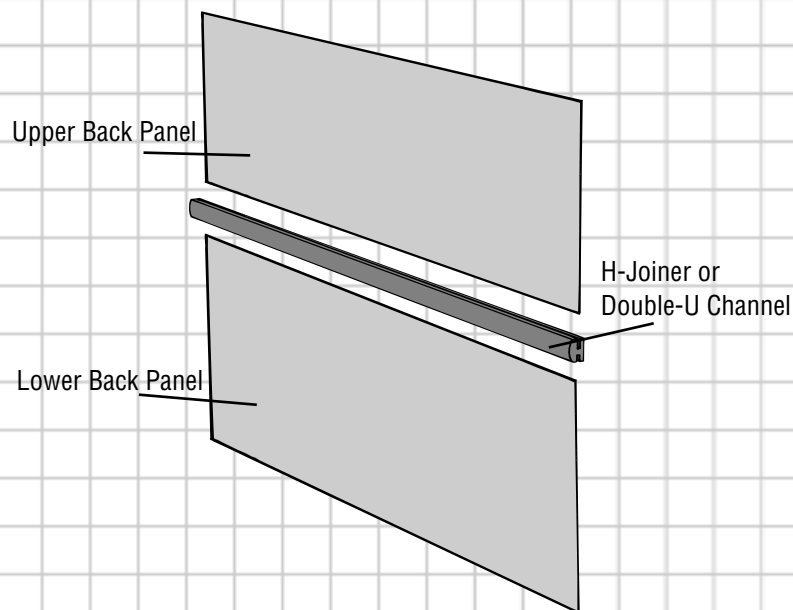

STEP 6: TOP CAPS

Tie units together by locking top caps over back panels and into adjacent uprights of shelving run.

STEP 7: KICKPLATES

Insert kickplates into the fronts of the baseshoes on adjacent uprights with the wide U-channel side towards the floor.

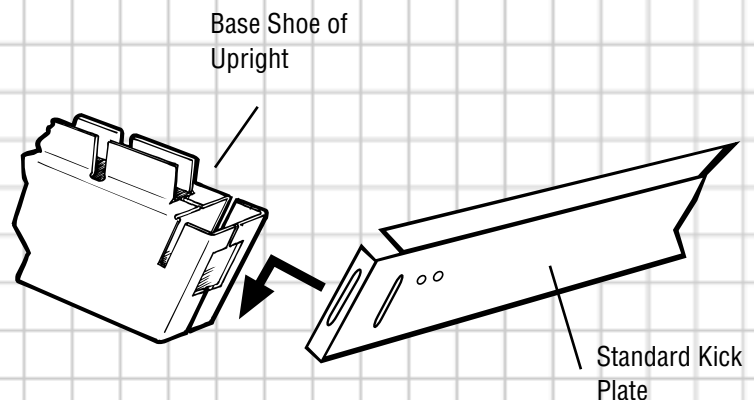

STEP 8: LEVELING UNIT

When using either the Storflex welded or detachable baseshoe shelving, level the shelving run by using either of the following two methods.

- Install one row of upper shelves, sight along shelf edge for straightness while leveling center and one outboard leveler bolt. Bring remaining outboard leveler bolts to floor then back off on upright leveler bolts to 1/8" above floor.
- Instead of using upper shelves as a sight line, use a string pulled taut over the length of the gondola run, the center leveler to align upright slots to the string, and a magnetic level to plumb the upright using the outboard levelers, followed by backing off all upright leveler bolts to 1/8" above the floor.

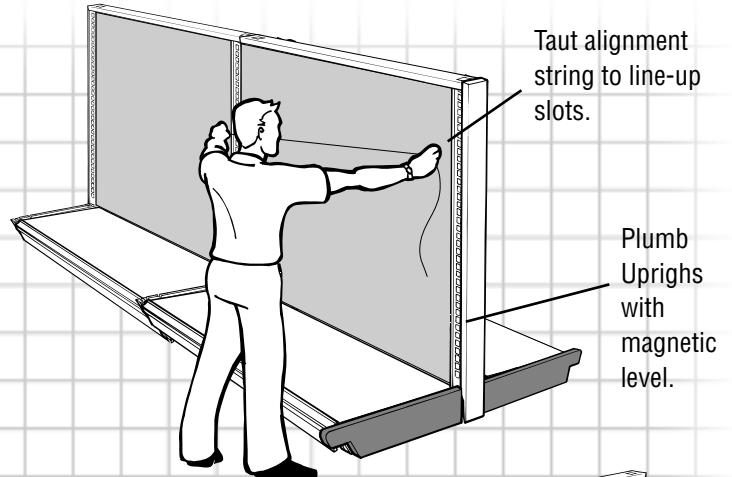

STEP 9: BASE SHELVES

A. WELDED BASESHOES with Gondola Guard™, bullnose or standard kickplates / baseshelves.

- Install the base shelf by placing the front out towards the aisle, engaging shelf end flanges into the baseshoe opening and sliding towards the back panel and downward into position.
- Where standard kickplates are used, it's suggested that they are slid upward away from the floor 1" before installing the base shelves. After bases are installed, slide kickplates down into place.

B. DETACHABLE BASESHOES with Gondola Guard™, extended base, or bullnose kickplates / baseshelves.

- Install base shelf by lining up the base shelf end bracket with the base shelf locking pin.
- Slide base shelf forward and downward in the direction of the movement arrows until the base shelf locks into position.

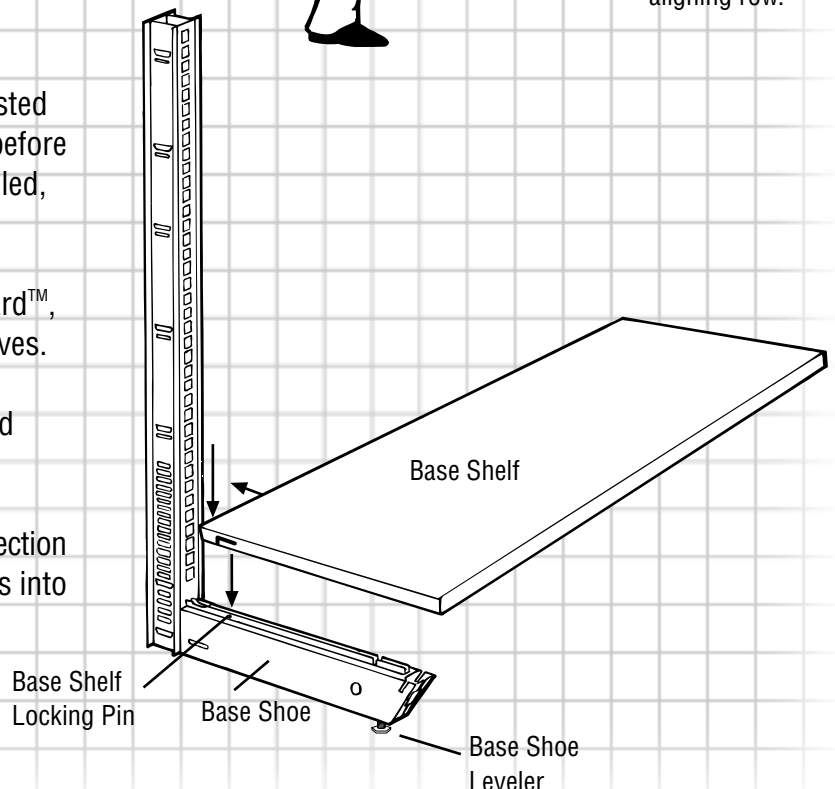
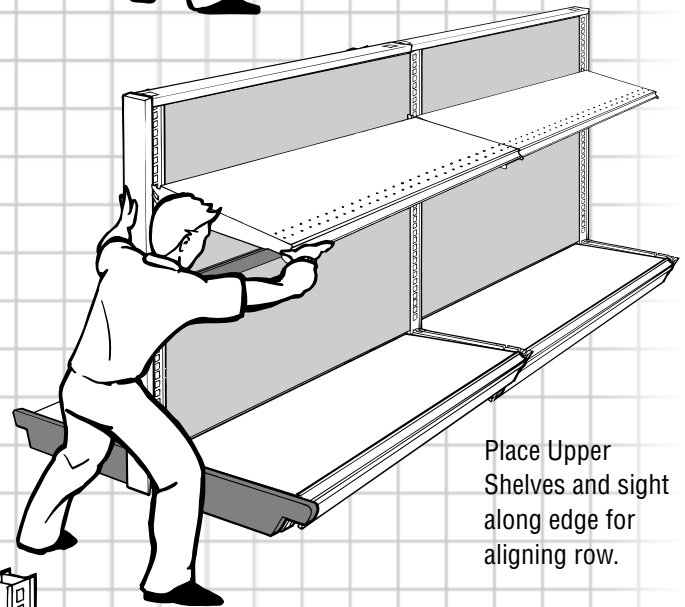

STEP 10: GONDOLA GUARD™ (Optional)

If your shelving system was ordered and supplied with the Storflex exclusive Gondola Guard™ feature, install as follows:

A. After installing kickplates, install Gondola Guard™ Extrusion into the receiver slot cut into each base shoe. Always start and end Gondola Guard™ Extrusions in line with the center of a base shoe.

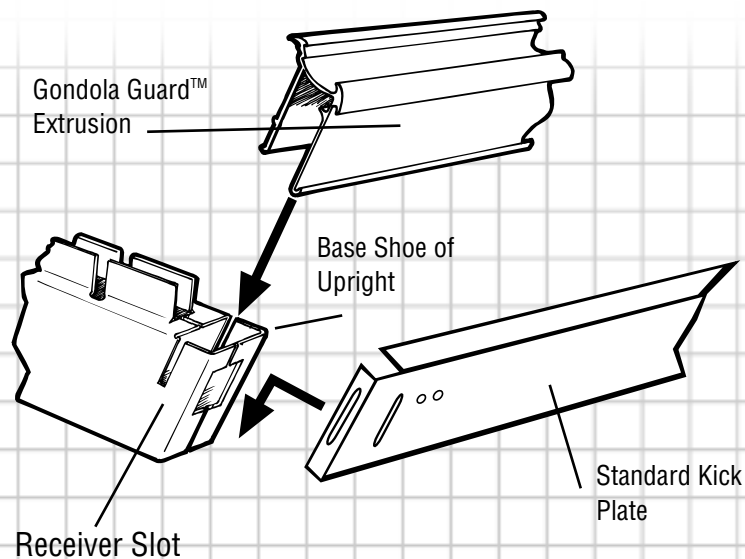

STEP 11: UPRIGHT AND BASE END COVERS

A. Refer to the first page illustration, "Identifying Parts."

B. Install upright end covers at both ends of shelving run to trim off the uprights.

C. Install base shoe end covers at each end of the run to trim off base shoes.

STEP 12: UPPER SHELVES

A. Install all upper shelves following your merchandising plan.

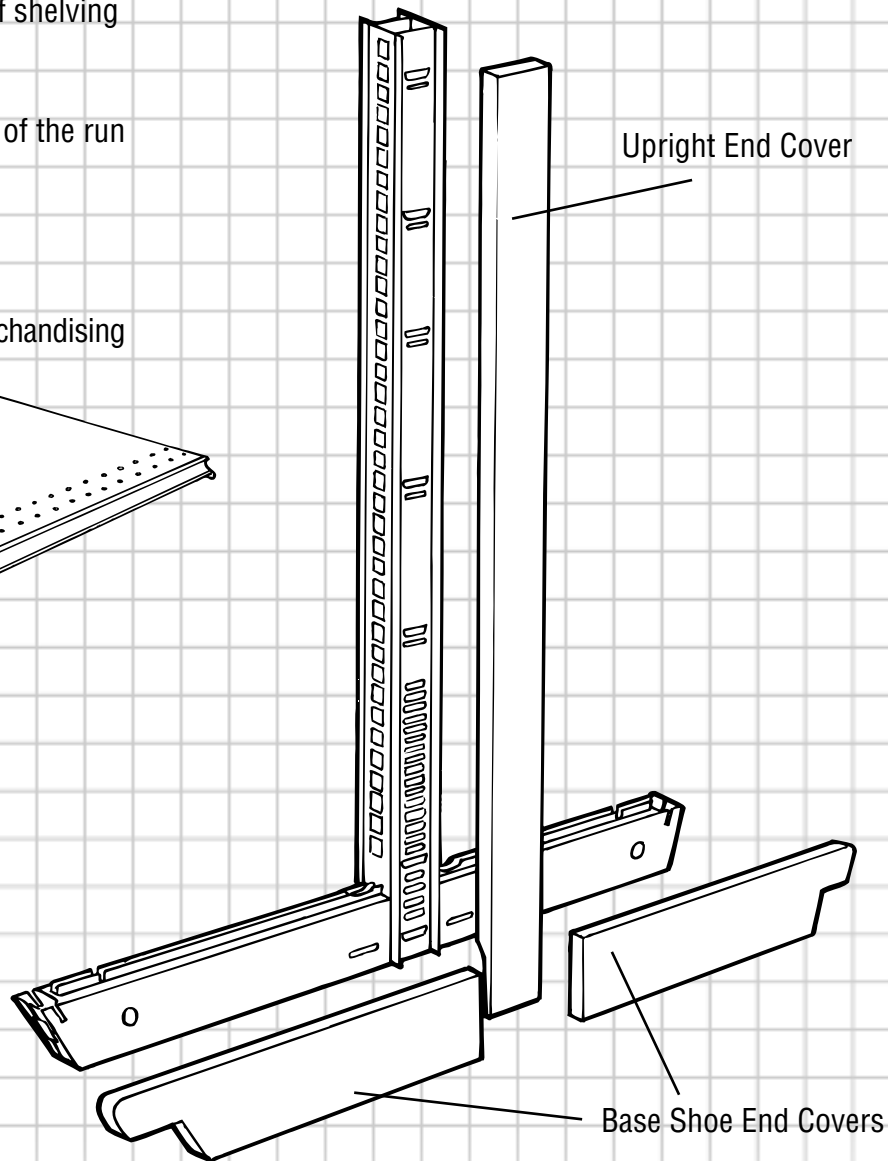
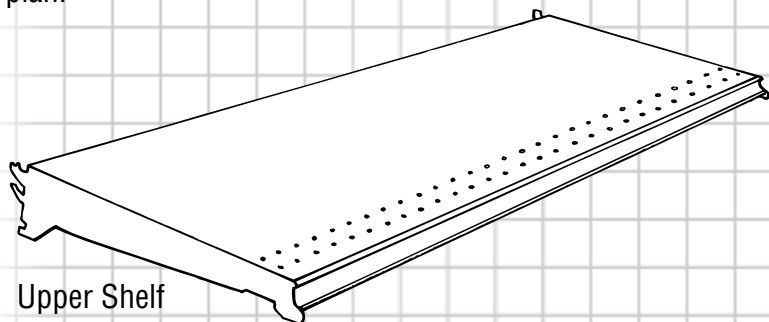

ADDENDUM

DEFINITION

An Offset Load is a condition where more weight is put on the shelves on one side of a shelving unit than on the other (disregarding base shelf load weights on either side). Half Gondolas (wall units) are always 100% offset loaded. Full Gondolas can be anywhere from 0% to 100% offset loaded. The result of this condition is leaning of the upright in the direction of the heaviest load. All competitive shelving marketed today leans when offset loaded. The measurement of the cause of the condition is called inch-pounds (in/lbs.) of loading and the measurement of the result is called deflection.

DETERMINATION AND CALCULATION INSTRUCTIONS

Determination of total inch-pounds of offset loading for comparison to STORFLEX ratings. Follow instructive examples below showing how to determine inch-pounds on fully (evenly) loaded shelves (**MARKED E**) and Forward loaded shelves (**MARKED F**). Also total offset loading.

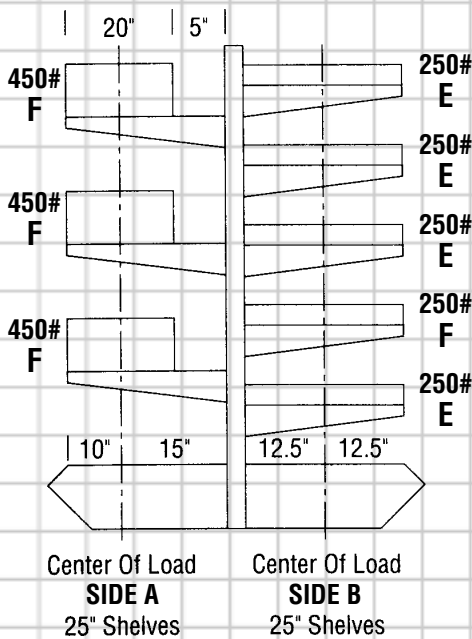

GONDOLA SHELVING

• Calculation Instructions:

A. Inch-Pounds = Distance in inches to center of load, multiplied times load in pounds.

B. Total Inch-Pounds **SIDE A** = 450#x15"x3 (shelves) = 20,250in/lbs

C. Total Inch-Pounds **SIDE B** = 25#x12.5"x5 (shelves) + 15,625 in/lbs

D. Total Inch-Pounds of offset load =

(**SIDE A**) minus (**SIDE B**) =

(20,250 in/lbs) - (15,625 in/lbs) = 4625 in/lbs

E. Unit will lean in direction of side A a deflection in inches as determined by referring to the Deflection Chart for 78" high units at approximately 4625 inch-pounds.

HALF GONDOLA SHELVING (WALL UNIT)

• Calculation Instructions:

A. Inch-Pounds = Distance in inches to center of load, multiplied times load in pounds.

B. Total Inch-Pounds side A =
in/lbs of upper shelves + in/lbs of lower shelves =
(350# x 17" x 3) + (400# x 13.5" x 3) = 34,050 in/lbs

C. All Wall Units lean toward loaded side.

D. Referring to deflection chart no reading is available for 90" units loaded to 34,050 in/lbs.

E. Referring to loading specifications it is noted that 24,000 in/lbs is the maximum allowable offset loading condition; 34,050 in/lbs exceeds this so unit cannot be loaded in this manner.

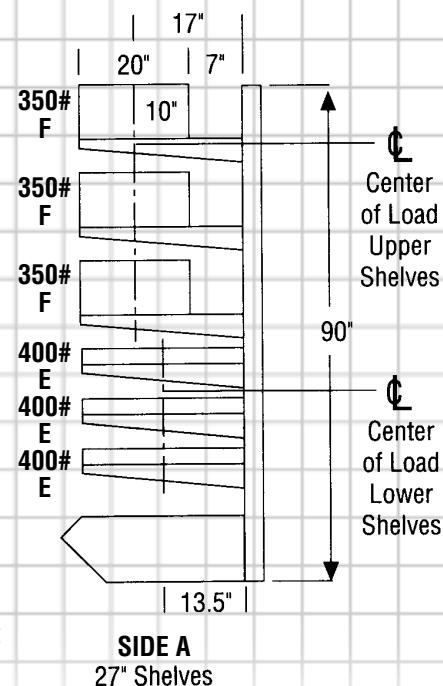

ADDENDUM

LEVELING SUGGESTIONS FOR OFFSET LOADED FULL AND HALF GONDOLAS

FACTS

A. All shelving sections lean when offset loaded.

B. Leaning sections progressively accentuate gaps between adjacent shelves as lean increases due to increased offset load applications. As long as offset loads do not exceed the “Loading Specifications” gaps do not indicate product failure.

C. To avoid “Leaning” its recommended to:

- Not forward load shelves.
- Keep balanced loading from side to side on full gondolas.
- Tie half gondolas to walls, fixed cases or floor.

SUGGESTIONS

A. If you can't live with the amount of lean range your merchandising plan gives you (see deflection chart), the apparent lean (visual part) can be minimized by the following:

- Do an inch-pound calculation for the shelving run under consideration.
- Determine the lean in inches from the deflection chart indicated.
- When assembling that shelving run, level it backwards leaning it away in the opposite direction an amount equal to the lean that the deflection chart indicated. This will give you a vertical shelving standard on the average, under load.

B. In order to minimize gaps between shelves on the offset loaded (heavily loaded side), the following can be done after product has been loaded on a shelving unit.

- Starting at and through the more lightly loaded uprights adjacent to where an unacceptable gap has occurred, lift the kickplates enough on both sides of the shelving run so that the levelers are accessible.
- Turn all of the levelers on the uprights down so they touch the floor.
- On the lightly loaded side turn the leveler up into the shoes.
- On the heavily loaded side of the shelving run turn the levelers out of the shoes and down into the floor until all uprights are plumb. this merely tips the upright/baseshoe assembly around its center leveler without creating any damaging forces and minimizes the shelf gap.
- Bring all of the levelers down out of the lightly loaded baseshoes until they touch the floor.
- **WARNING! DO NOT ATTEMPT ANY OTHER TYPE OF LEVELING METHOD ON A LOADED SHELVING UNIT.**

ADDENDUM

LOADING SPECIFICATIONS

These specifications assume that all steps in the assembly instructions have been followed correctly. Each specification stands independently on its own statement.

- Maximum Total "Column Loading" of any length section (36', 48" etc.) Assumes loading consists of "sum" of all weight in pounds placed on all Base and Upper Shelves.

- Full Gondola: 6,000 pounds
- Half Gondola: 4,000 pounds

- Maximum Total "Offset Loading" of any single or one of a consecutive series of shelving uprights.

- Full Gondola: 24,000 in/lbs
 - Half Gondola: 24,000 in/lbs
- } With a safety factor of 1.67

- Each "type" of shelf is individually rated for maximum carrying capacities as shown in catalog.

DEFLECTION CHART

Inch-Pounds of Offset Load	Deflection measured in inches (lean) away from a starting point at top of specific height upright.							
	48"	54"	60"	66"	72"	78"	84"	90"
2000	1/32"	3/64"	1/16"	1/16"	5/64"	5/64"	3/32"	3/32"
4000	1/16"	5/64"	3/32"	1/8"	9/64"	9/64"	5/32"	5/32"
6000	1/8"	5/32"	11/64"	13/64"	7/32"	15/64"	1/4"	17/64"
8000	3/16"	7/32"	15/32"	1/4"	9/32"	5/16"	11/32"	23/64"
10,000	5/16"	11/32"	3/8"	27/64"	15/32"	1/2"	9/16"	37/64"
12,000	3/8"	13/32"	15/32"	1/2"	21/32"	5/8"	21/32"	11/16"
14,000	1/2"	9/16"	5/8"	11/16"	3/4"	13/16"	7/8"	15/16"
16,000	9/16"	5/8"	23/32"	25/32"	7/8"	57/64"	63/64"	1-1/16"
18,000	23/32"	25/32"	29/32"	63/64"	1-1/16"	1-5/64"	1-1/14"	1-11/32"
20,000	25/32"	7/8"	63/64"	1-1/16"	1-3/16"	1-9/32"	1-3/8"	1-15/32"
22,000	27/32"	31/32"	1-1/16"	1-11/64"	1-9/32"	1-13/32"	1-1/2"	1-5/8"
24,000	15/16"	1-1/32"	1-5/32"	1-9/32"	1-13/32"	1-1/2"	1-5/8"	1-3/4"